

CZ Engineering, Inc.

"Craftsmanship & Innovation"

33863 Highway E
Dixon, MO 65459
(573) 759-2144 (800) 851-0444 fax (573) 759-2147
email: sales@cze.com - Web Site: www.cze.com



Explanation of Interdependency of Options Relating to the Integral Reel Racks and Rear Telescopic Extender

When the tongue is fully retracted, as shown here, the inner 8" tube protrudes 3' out the rear end of the trailer, limiting the forward travel of the Rear Telescopic Extender.

Without the longer (6') Extended Storage Area, the Rear Telescopic Extender only moves forward 5', leaving a 3' extension past the rear of the trailer, as shown here.

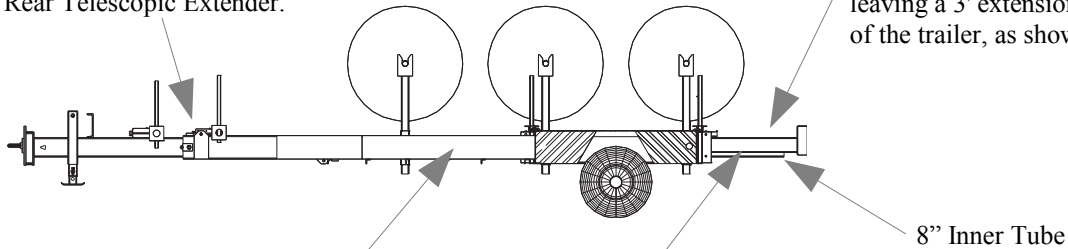

To mount the fore-most reel, the Extended Storage Area must have 6' flat sides instead of the normal 3' flat sides.

These twin rails move in and out of the Extended Storage Area. If the storage area is not long enough, their travel is limited.

In order to move the Rear Telescopic Extender all the way forward (as shown), the tongue must be extended to at least the second position.

The longer (6') Extended Storage Area allows the Rear Telescopic Extender to move farther forward.

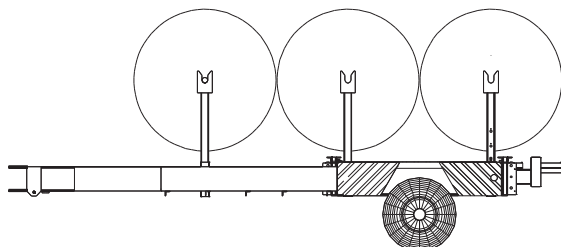
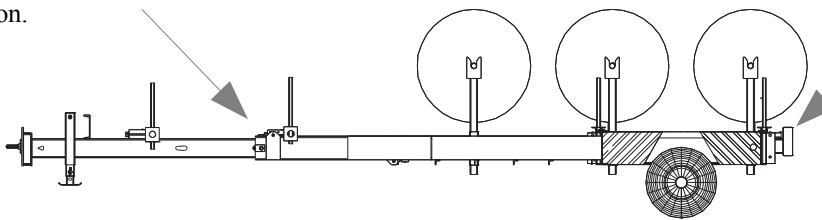

Shown with 58" spools & 6" taller uprights.

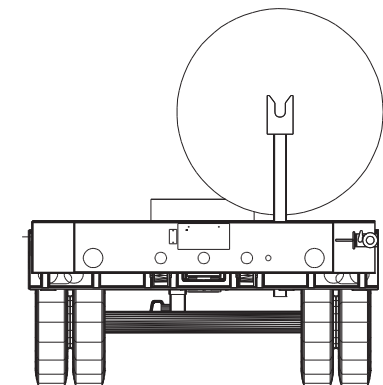

Shown with 48" spool.